

Hup 40-30

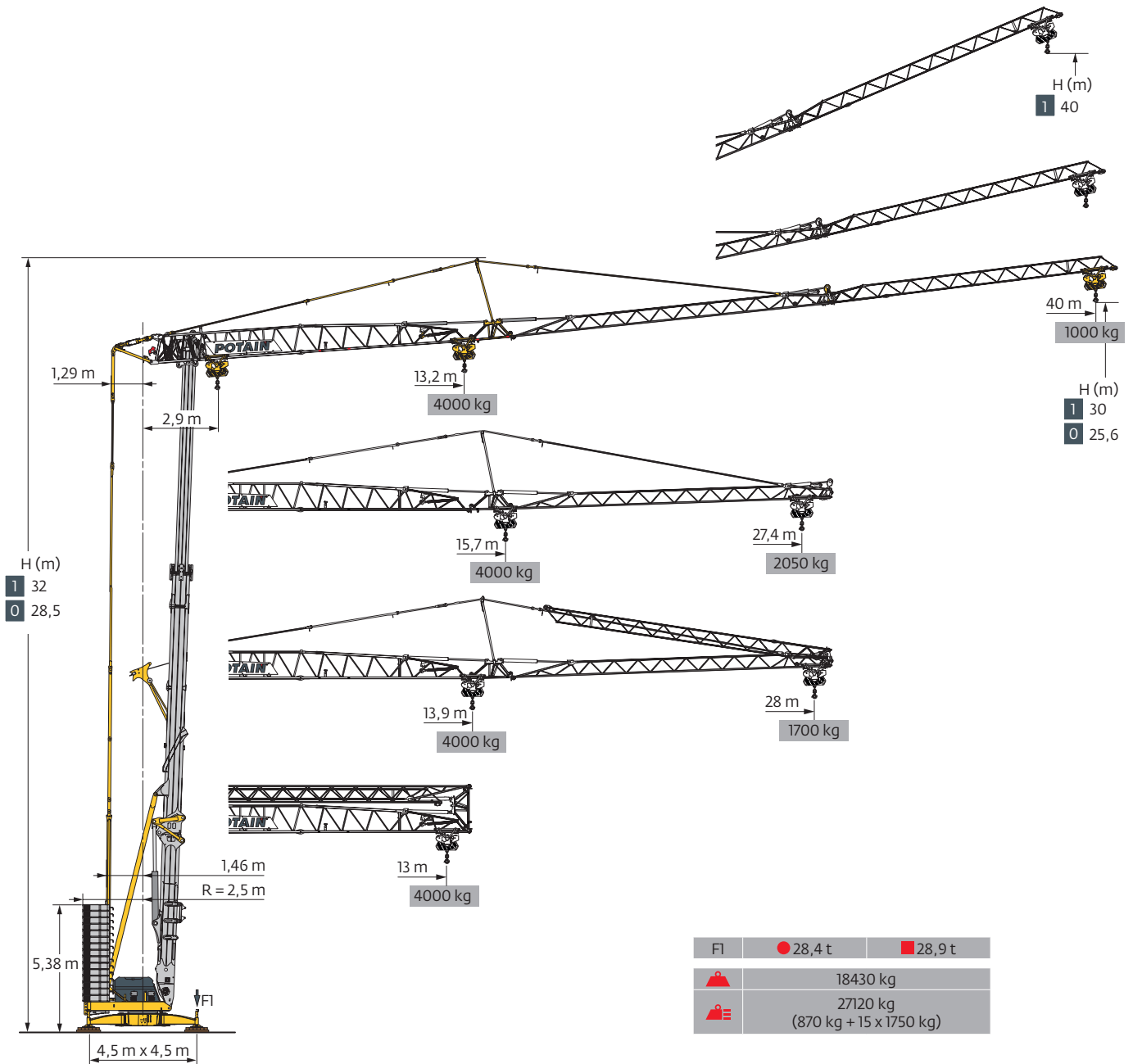

Courbes de charges / Lastkurven / Load curves / Curvas de cargas / Curve di carico
 Curvas de carga / Кривые нагрузок

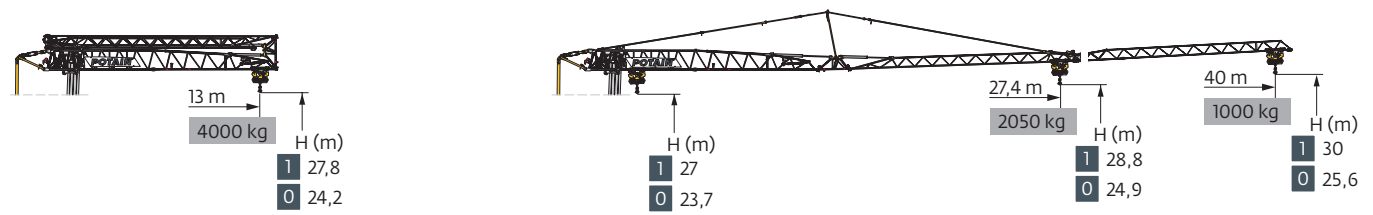

| | | | | | | |
|--------|-----|---|----|---|------|----|
| 40 m | 2,9 | ▶ | 13 | m | 4000 | kg |
| 27,4 m | 2,9 | ▶ | 13 | m | 4000 | kg |

| | | | | | | | | | | | | | | | | | | |
|------|------|------|------|------|------|------|------|------|------|------|------|------|------|------|------|----|----|---|
| 2,9 | ▶ | 13,2 | 14 | 15 | 16 | 17 | 18 | 19 | 20 | 22 | 25 | 27 | 30 | 32 | 35 | 37 | 40 | m |
| 4000 | 3700 | 3400 | 3150 | 2950 | 2750 | 2550 | 2400 | 2150 | 1800 | 1650 | 1450 | 1350 | 1200 | 1100 | 1000 | kg | | |

| | | | | | | | | | | | |
|------|------|------|------|------|------|------|------|------|----|------|---|
| 2,9 | ▶ | 15,7 | 16 | 17 | 18 | 19 | 20 | 22 | 25 | 27,4 | m |
| 4000 | 3900 | 3650 | 3400 | 3200 | 3000 | 2650 | 2300 | 2050 | kg | | |

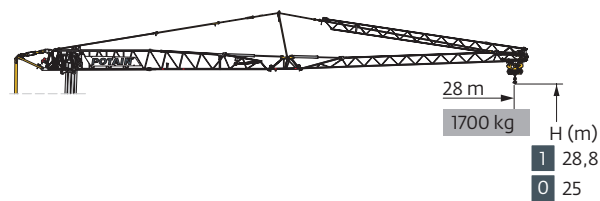

| | | | | | | | | | | | | | | | |
|------|------|------|------|------|------|------|------|------|------|------|------|----|----|----|---|
| 40 m | 2,9 | ▶ | 13,9 | 14 | 15 | 16 | 17 | 18 | 19 | 20 | 22 | 25 | 27 | 28 | m |
| 4000 | 3950 | 3650 | 3350 | 3150 | 2900 | 2750 | 2550 | 2300 | 1950 | 1800 | 1700 | kg | | | |

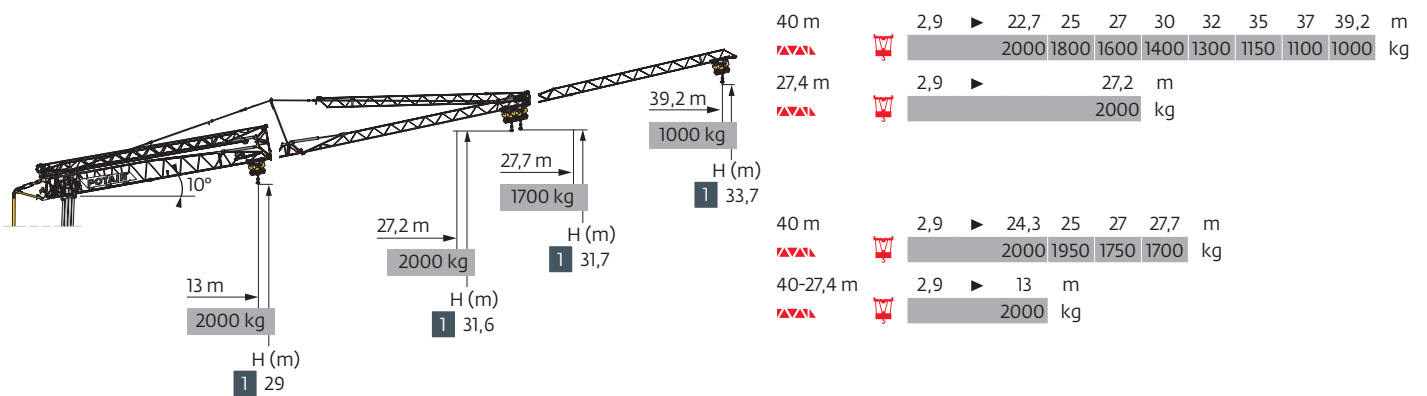

| | | | | | | | | | | | |
|------|------|------|------|------|------|------|------|----|----|------|---|
| 40 m | 2,9 | ▶ | 22,7 | 25 | 27 | 30 | 32 | 35 | 37 | 39,2 | m |
| 2000 | 1800 | 1600 | 1400 | 1300 | 1150 | 1100 | 1000 | kg | | | |





| | | | | |
|--------|-----|---|------|---|
| 27,4 m | 2,9 | ▶ | 27,2 | m |
| 2000 | kg | | | |

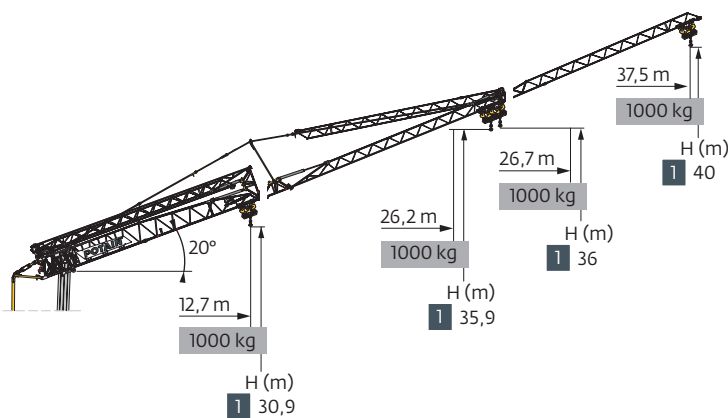



| | | | | | | | |
|------|------|------|------|----|----|------|---|
| 40 m | 2,9 | ▶ | 24,3 | 25 | 27 | 27,7 | m |
| 2000 | 1950 | 1750 | 1700 | kg | | | |

| | | | | |
|-----------|-----|---|----|---|
| 40-27,4 m | 2,9 | ▶ | 13 | m |
| 2000 | kg | | | |



Mécanismes / Triebwerke / Mechanisms / Mecanismos / Meccanismi
 Mecanismos / Механизмы

| 400 V - 50 Hz 480 V - 60 Hz | | |  | | | | | ch - PS hp | kW |
|---|-------------------|------------------------|---|------|------|------|-----|---------------|---------|
|  | 18 HPL™ 10 | m/min | 1,7 | 19 | 36 | 58 | 65 | 18 | 13 |
| | | kg | 4000 | 4000 | 2000 | 1000 | 500 | | |
|  | 3 DVF 5 | m/min | 1 → 45 (0 → 1000 kg) 1 → 41 (1000 → 4000 kg) | | | | | 3 | 2,2 |
|  | HPS 142 | tr/min U/min rpm | 0 → 0,9 | | | | | 2 x 5 | 2 x 3,7 |

|  IEC 60204-32 |  kVA |  |
|--|---|---|
| 400 V (+10% -10%) 50 Hz 480 V (+6% -10%) 60 Hz | 23 → 17 kVA |  |

Montage / Montage / Erection / Montaje / Montaggio
 Montagem / Монтаж

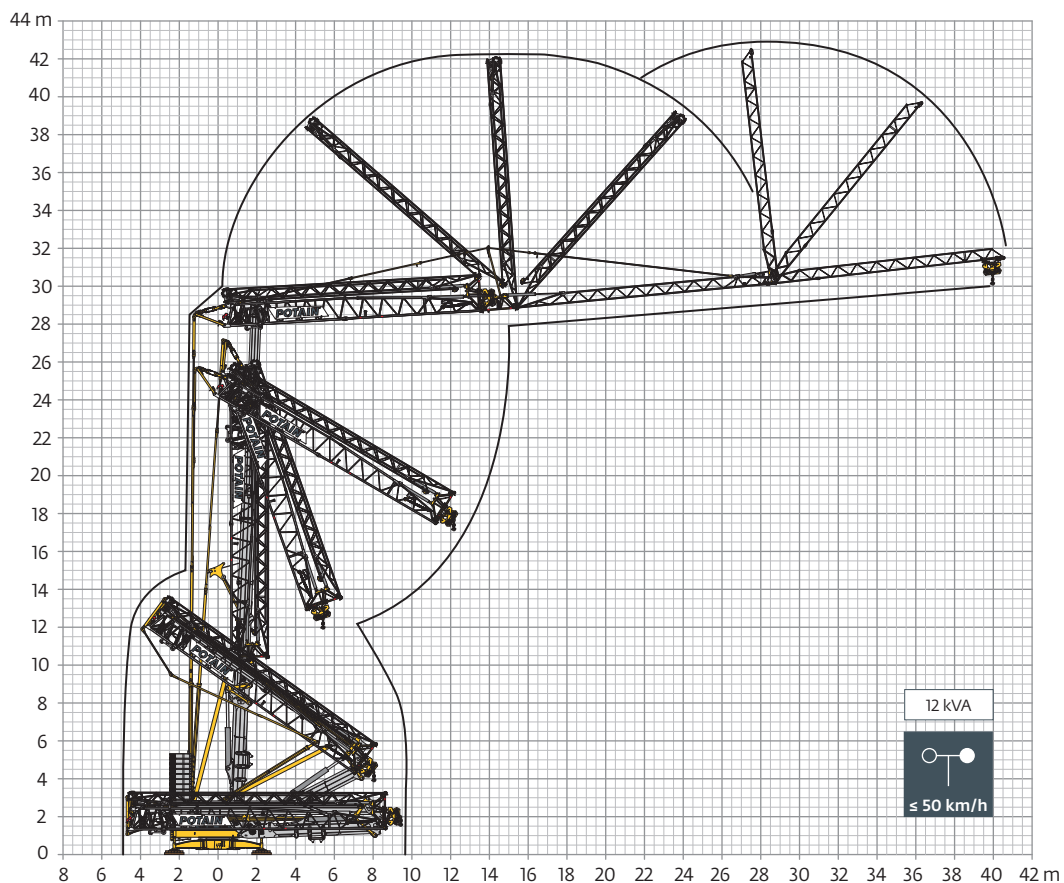

Transport / Transport / Transport / Transporte / Trasporto
Transporte / Транспортировка

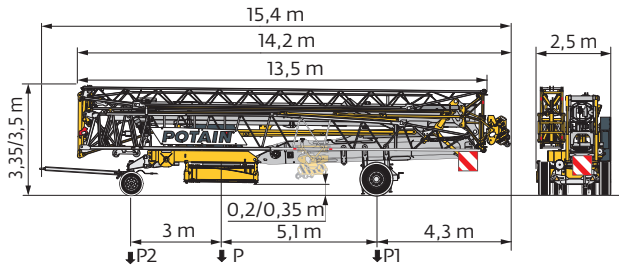

| | km/h | P (kg) | P1 (kg) | P2 (kg) |
|------------|------|--------|---------|---------|
| DJ100/S120 | 10 | 20320 | 11870 | 8450 |
| DJ105/S125 | 25 | 20580 | 11980 | 8600 |

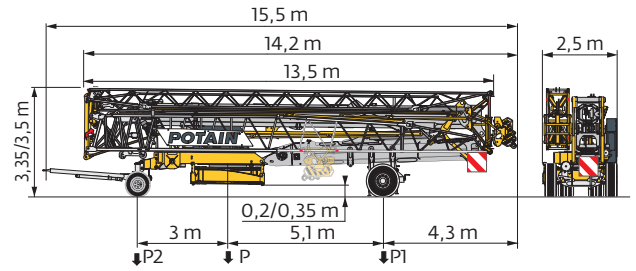

| | km/h | P (kg) | P1 (kg) | P2 (kg) |
|----------------|------|--------|---------|---------|
| DJ126M/S125 | 25 | 20780 | 12000 | 8780 |
| /..... ⓘ | | | | |

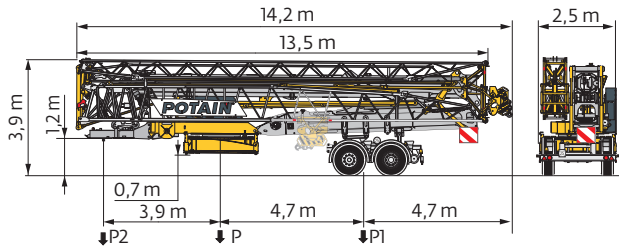

| | km/h | P (kg) | P1 (kg) | P2 (kg) |
|-------------|------|--------|---------|---------|
| SL121/S215M | 25 | 21880 | 14710 | 7170 |

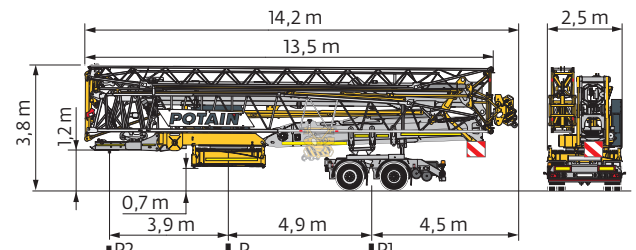

| | km/h | P (kg) | P1 (kg) | P2 (kg) |
|--|------|--------|---------|---------|
| SL122/J215M (EBS) RCE e2*2007/46*0493*01 WVTA e2*2007/46*0493*01 | 80 | 21680 | 14510 | 7170 |

| | FR | DE | EN | ES | IT | PT | RU |
|------------|---|--|---|---|---|--|--|
| R | Rayon de giration | Schwenk radius | Rear slewing radius | Radio de giro | Raggio di rotazione | Raio de rotação | Задний габарит |
| ⓘ | Nous consulter | Auf Anfrage | Consult us | Consultarnos | Consultateci | Consultar-nos | Проконсультируйтесь у нас |
| ● | Réactions en service | Reaktionskräfte in Betrieb | Reactions in service | Reacciones en servicio | Reazioni in servizio | Reacções em serviço | Реакция при работе |
| ■ | Réactions hors service | Reaktionskräfte außer Betrieb | Reactions out of service | Reacciones fuera de servicio | Reazioni fuori servizio | Reacções fora de serviço | Реакция в покое |
| ⚖ | Poids à vide, sans lest, sans trains de transport, avec flèche maxi. et hauteur standard. | Gewicht ohne Last, ohne Ballast, ohne Transportachsen, mit max. Auslager und Standardhöhe | Weight without load, without ballast, without transport axes, with max. jib and standard height | Peso en vacío, sin lastre, sin trenes de transporte con flecha y altura estandar | Peso a vuoto, senza zavorra, senza assali di trasporto, con braccio max e altezza standard. | Peso em vazio, sem lastro, sem eixos de transporte com lança máxima e altura standard. | Вес без груза, без балласта, без осей для транспортировки, с максимальным вылетом стрелы и стандартной высотой |
| ⚖ | Poids total du lest | Ballast-Gesamtgewicht | Total ballast weight | Peso total del lastre | Peso totale della zavorra | Peso total do lastro | Общий вес балласта |
| □ | Équipements standards | Standardausrüstungen | Standard equipment | Equipamiento de serie | Equipaggiamento standard | Equipamento de série | Стандартное оборудование |
| ⊞ | Équipements optionnels | Sonderausrüstungen | Options | Equipamiento opcional | Equipaggiamento in opzione | Equipamento opcional | Дополнительное оборудование (опция) |
| ⬆ | Levage | Heben | Hoisting | Elevación | Sollevarmento | Elevação | Подъем |
| ➡ | Distribution | Katzfahren | Trolleying | Distribución | Distribuzione | Distribuição | Перемещение по стреле |
| ⬅ | Orientation | Schwenken | Slewing | Orientación | Rotazione | Rotação | Поворот |
| kVA | Puissance requise | Erforderliche Leistung | Required power | Potencia Necesaria | Potenza richiesta | Potência Necessária | Потребляемая мощность |
| ⊞ | Fonction Power Control : vitesses treuils adaptées à la puissance disponible | Funktion Power Control: Geschwindigkeiten der Triebwerke werden an die verfügbare Leistung angepasst | Power Control Function: winch speeds adapted to the available power | Función Power Control: marchas de los cabrestantes adaptadas a la potencia disponible | Funzione Power Control: velocità degli argani adattate alla potenza disponibile | Função Power Control: velocidades de guincho adaptadas à potência disponível | Функция контроля мощности Power Control: регулировка скорости лебедок в зависимости от доступной мощности |

| | | | | | | | |
|----------|--|--|---|--|--|---|--|
| ⚠ | Hauteurs sous crochet données moufle plaquée | Hakenhöhen werden mit plattiertem Haken angegeben | Hook heights given with plated pulley block | Altura bajo gancho con pasteca bloqueada | Altezza sotto gancio con bozzello in contatto con carrello | Altura ao gancho com o cadernal em contacto com o carrinho | высота под крюком дана при условии, что крюковая подвеска соприкасается с кареткой |
| | Document commercial non contractuel | Unverbindliches Vertriebsdokument | This commercial document is not legally binding | Documento comercial no contractual | Documento commerciale non vincolante | Documento comercial não contratual | Этот коммерческий документ не является юридически обязательным |
| | Pour toute information technique se référer à la notice correspondante | Für technische Informationen, siehe die entsprechenden Anweisungen | For any technical information, please refer to the corresponding instructions | Para cualquier información técnica, ver la noticia correspondiente | Per tutte le informazioni tecniche fare riferimento al catalogo istruzioni | Para qualquer informação técnica complementar consultar as respectivas instruções | Для получения технической информации, см. соответствующие инструкции |

